

BFH Energy Storage Research Centre

Infrastructure

Test equipment

Cell and module testers

Our battery testers stand at the core of our battery research and development activities. Today, our battery test equipment comprises a total of 79 testing channels. In other words, up to 79 battery cells, modules or packs can be put to the test simultaneously.

Tester	Channels	Upper voltage limit
ACT0550	60	5 V
SBT10050	12	100 V
Evaluator-B	7	5 V, 35 V & 100 V

All our test equipment combines very high control and measurement accuracy with an excellent dynamic behavior. The software allows end users to download and run pre-recorded CSV files on the test channels. This way the system can simulate complex load patterns. This results in very precise, near real time simulations of demanding applications in electro-mobility, renewable energy, defense and aeronautics.

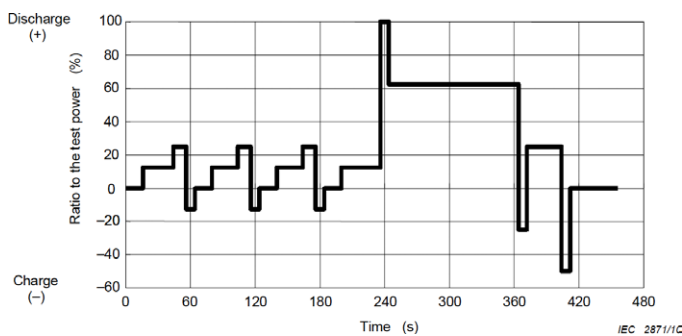

Source: IEC62660-1, Dynamic discharge profile for BEV

Newest test equipment specifications

Our newest testers, the 60-channel high power cell tester and the 12-channel module tester are ideal for testing and evaluating cells and modules for high speed and accuracy demanding applications. These systems support current, voltage, power and resistive based loads, with a minimum pulsing width of 1 msec. The testers have also ultra-fast switching capabilities between charging and discharging modes. All 50 A channels on both testers can also be connected in parallel to achieve higher charging or discharging currents.

General Characteristics

- 4-point measurement, 72 channels
- Sampling frequency: 1 msec (100 µsec internal)
- Rise, fall & switch time: < 1 µsec (typically 100 µsec)

Voltage

- Range: 0 to + 5 Vdc & 0 to + 100 Vdc
- Control accuracy: ±0.05% FSD
- Measurement acc.: ±0.005% FSD

Current

- Range: 0 to 50 A (4 automatic switched current ranges 50 mA, 500 mA, 5 A and 50 A)
- Control accuracy: ±0.03% FSD in each range
- Resolution: 1 µA (range 50 mA), 10 µA, range (500 mA), 100 µA (range 5 A), 1mA (range 50 A)



Battery management system integration

The Auxiliary IO's offer a powerful platform for creating interfaces to BMS system's controllers over either CANbus, SMBus, RS485 or USB.

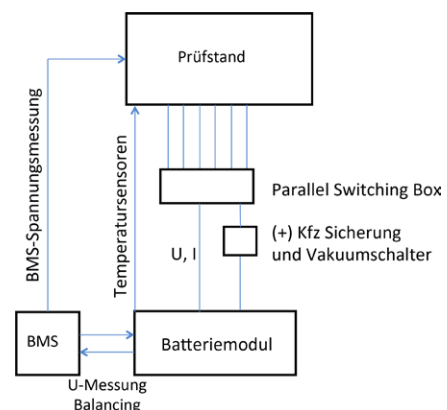

Datapoints such as current and voltage can be set and collected over this interface and used in the test programs. Temperature readings from the BMS can also be collected for later analysis.

Temperature test chambers

Throughout their lifespan, batteries are exposed to varying thermal and climatic conditions which affect the properties, functionality and ultimately their performance. Thus, during their early production stage, it must be ensured that batteries meet minimum performance and safety requirements to guarantee a reliable operation even under extreme conditions, such as heat or cold. Temperature test chambers simulate the environmental conditions and reliably check the battery's durability and safety. The battery laboratory at BFH Energy Storage Research Centre is equipped with 10 temperature chambers; most of them can operate between - 40 °C and over 80 °C with temperature rates of change of ca. 2 K / min, and spatial and temporal deviations of less than 1.5 K and 0.5 K, respectively.

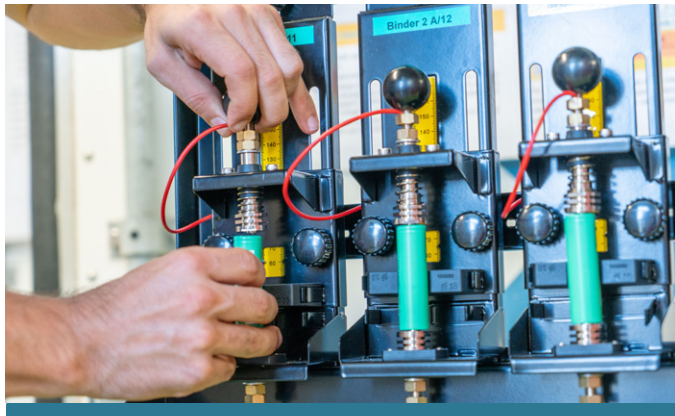

Brand	Capacity	Quantity
ESPEC	105 L	1
ESPEC	1'100 L	3
Vötsch	37 L	1
Vötsch	110 L	2
CTS	400 L	1
Jianqiao	408 L	1
Binder	730 L	1
Container	12'445 L	1

Highly accurate temperature sensors

Test and battery quality monitoring is continuously done using external and highly accurate temperature sensors. For this, two or more sensors are positioned on the surface of each sample or in the case of a battery module or pack at sites where e. g. "hot spots" are expected. The Pt100 sensors used in our lab are not only highly accurate (± 0.07 °C), but also highly responsive ($t_{90} < 1.0$ s) thanks to their very small size of 1.3 x 2.0 x 2.0 mm, which allows monitoring rapid surface temperature variations caused by testing at high power (e. g. racing EVs).

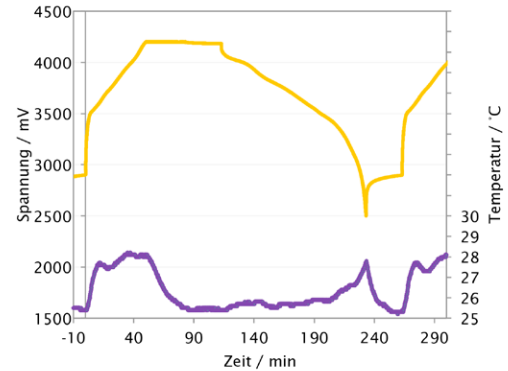

Infrared camera

Thermal imaging is used to check for «hot spots» i. e. to indicate points of high thermal stress in the cell or the battery pack. Tests with our FLIR E6 camera can help to identify problems such as overheating, inadequate heat sinking or air flow, undersized current conductors and interference from neighbouring cells or devices (see our image below). The images can also be used to determine the best location for placing temperature sensors in protection circuits.

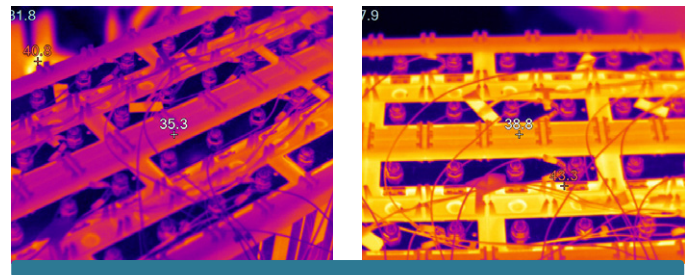

BFH Energy Storage Research Centre

The BFH Energy Storage Research Centre unites several research groups of the Bern University of Applied Sciences.

Contact

Prof. Dr. Andrea Vezzini
Head of BFH Energy Storage Research Centre
Aarbergstrasse 5, 2560 Nidau
andrea.vezzini@bfh.ch