

## Measuring Principle of line absorption spectroscopy (LDS 6 Siemens, with diode laser as light source)

The LDS 6 measures the gas concentration by using line absorption spectroscopy. If the absorption of gas mixture is plotted versus the wavelength, it can be seen that absorption only takes place at certain wavelengths in the spectral region. These extremely narrow absorption peaks are referred to as absorption lines as shown in the figure below.

The measured gas (here ammonia, figure 1) is identified by comparing with the spectrum from a built in reference cell. To perform line absorption spectroscopy, the LDS 6 uses a diode laser as light source since its spectral width is much narrower than the width of the absorption line. Furthermore, the wavelength of the laser can be selected to be near one absorption line of the gas to be measured. By varying the current and temperature the laser wavelength is tuned to cover the required narrow spectral range which includes the absorption line. When tuning the laser light over the absorption line it is partially absorbed. From the received laser signal the area beneath the absorption line can be extracted, which is a measure of the gas concentration.

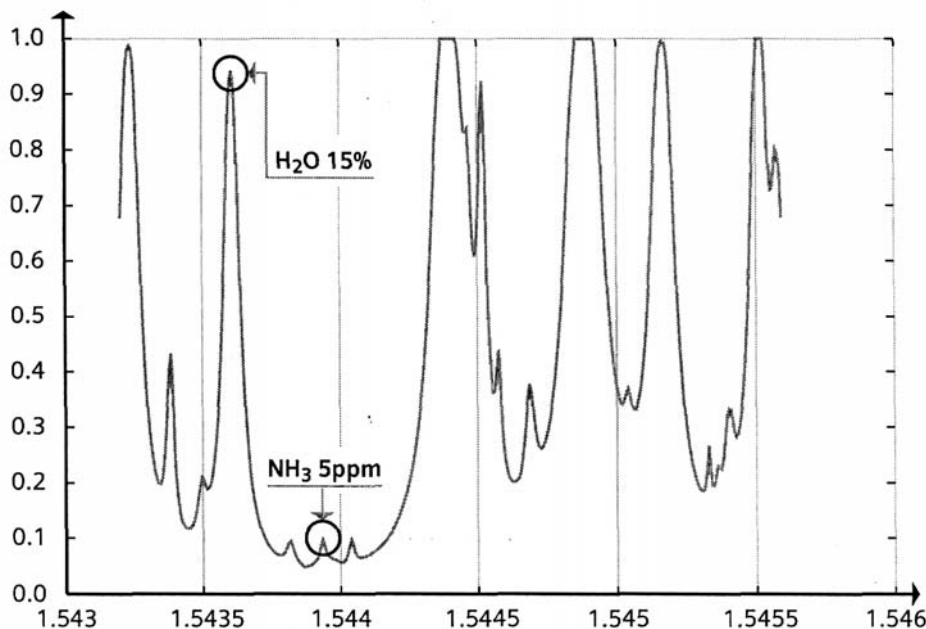

**Figure 1: Absorption lines**

[source: Siemens LDS6 manual]

The light emitted from the laser is split into five beams. The first beam passes through a reference gas and is then detected. This reference signal is used for continuous self-calibration and zero point determination of the system, taking temperature and pressure into account. The second beam is used for measuring the intensity of the laser and provides the control unit with Information relating to the state of the laser. The third, fourth and/or fifth beams (depending on how many channels are in use) are conducted via the optical fiber with the E2000 connectors to the sensor heads, where it enters the measuring sections. When the laser light passes through the gas in the measuring section it is partially absorbed. The light is detected by the receiver and after signal conditioning it is converted to an optical signal and returned to the central unit using the multi mode optical fiber (with the SMA connectors).

The concentration of the measured gas is calculated from the absorption spectrum for the measurement channel (PT, figure 2). Any change in the measurement conditions, for example as a result of a higher dust load in the flue gas or contamination of the optical components, is compensated for automatically to guarantee the accuracy of the measurement results under a wide range of operating conditions.

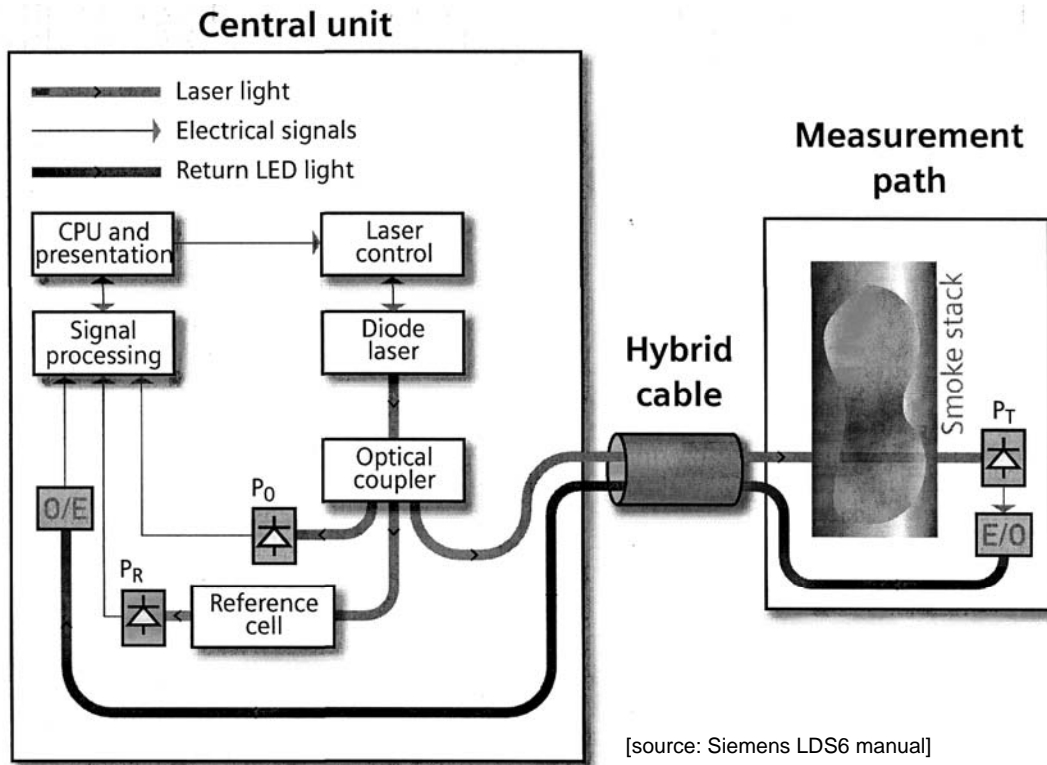
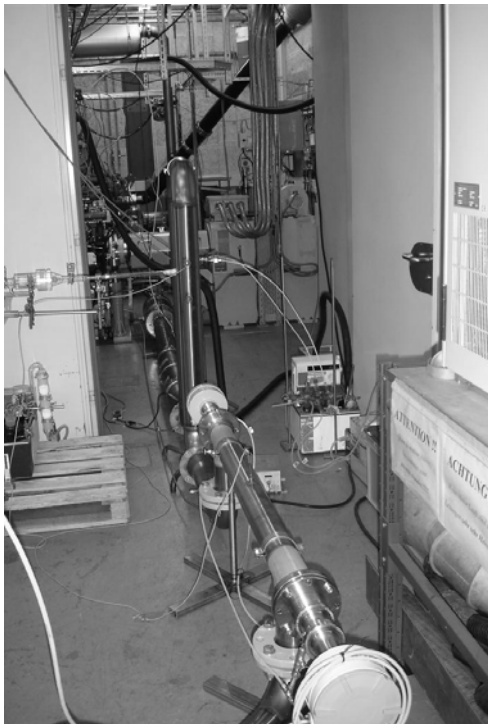

Figure 2: Block diagram of LDS 6



[source: AFHB]

Figure 3: LDS6 sensors in the exhaust duct of the research engine